



SUSPENSION & RECOVERY GEAR RANGE 2026

Premium Performance. Built for New Zealand. Proven Worldwide.



3 Year
Limited Warranty



NZ
Owned



Built
for 4WD

WWW.XTREMEGRAVELGEAR.COM



ABOUT OUR COMPANY

New Zealand owned. Built for 4WD adventure.

Xtreme Gravel Gear® is a New Zealand owned and operated company specialising in 4WD suspension and off-road recovery gear. We are passionate about delivering high-quality products that meet the needs of off-road enthusiasts, trade professionals, and everyday adventurers alike. Our team is committed to ongoing research and development, ensuring our products remain at the forefront of off-road technology.

We pride ourselves on listening to customer feedback and using real-world experience to develop products that are functional, durable, and built to perform in demanding conditions. Our goal is to provide the ultimate 4WD gear so our customers can tackle any terrain with confidence.

Our product range includes shock absorbers, coilovers, leaf springs, and a wide variety of off-road recovery gear, including winches, recovery straps, and accessories. Every product is engineered to high quality standards and rigorously tested to meet our strict performance expectations.

We stand behind our products with exceptional customer service, technical support, and practical advice to help customers choose the right solution for their vehicles and adventures. Xtreme Gravel Gear® is proud to support off-road enthusiasts across New Zealand and beyond.

OUR STORY

Established in 2019, Xtreme Gravel Gear was born from a genuine passion for 4WDing and a drive to create products that could withstand harsh off-road conditions.

After years of testing, development, and refinement, the brand was officially registered as Xtreme Gravel Gear in 2022.

Built around strict personal standards for quality, durability, and performance, the brand continues to grow with a focus on real-world reliability and innovation.



ESTABLISHED
2019



OFFICIALLY
REGISTERED
2022



NZ OWNED
& OPERATED



SUSPENSION
& RECOVERY
SPECIALISTS

WHAT WE DO



4WD SUSPENSION
SYSTEMS



SHOCK ABSORBERS
& COILOVERS



LEAF
SPRINGS



RECOVERY GEAR
& ACCESSORIES



TECHNICAL SUPPORT
& PRODUCT
DEVELOPMENT



GLOBAL FOOTPRINT

Regional strength. Worldwide reach.

Xtreme Gravel Gear™ is proud to be sold globally, supported by independently owned regional offices in strategically positioned markets including South Africa, Kuwait, Spain, the United States and our Head Office in New Zealand. Together, this network helps distribute our products to more than 180 countries worldwide — a testament to our continued brand development, growth and the strength of our partnerships.

Our expanding global footprint reflects the trust placed in the Xtreme Gravel Gear™ brand and our commitment to supplying high-quality 4WD suspension and recovery solutions to customers around the world. Through strong partnerships and regional support, we continue to grow our presence across international markets while staying true to our New Zealand roots.



180+
COUNTRIES
REACHED



**INDEPENDENT
REGIONAL
OFFICES**



**GLOBAL
BRAND
GROWTH**



180+
Countries Reached



**Strategic
Regional Offices**



**Strong
Global Partnerships**



XTREME GRAVEL GEAR SUSPENSION RANGE

Engineered for 4WD performance across touring, towing, overlanding and off-road conditions.

INTRODUCING OUR SUSPENSION RANGE

Built for 4WDs, SUVs and pick-up trucks, Xtreme Gravel Gear suspension is engineered for performance, durability and control.

Proudly designed in New Zealand and trusted by drivers who demand more from every journey.

**BUILT TO PERFORM.
READY FOR ANY TERRAIN.**



**BUILT TOUGH.
BUILT FOR 4WD.**



**DESIGNED IN
NEW ZEALAND**

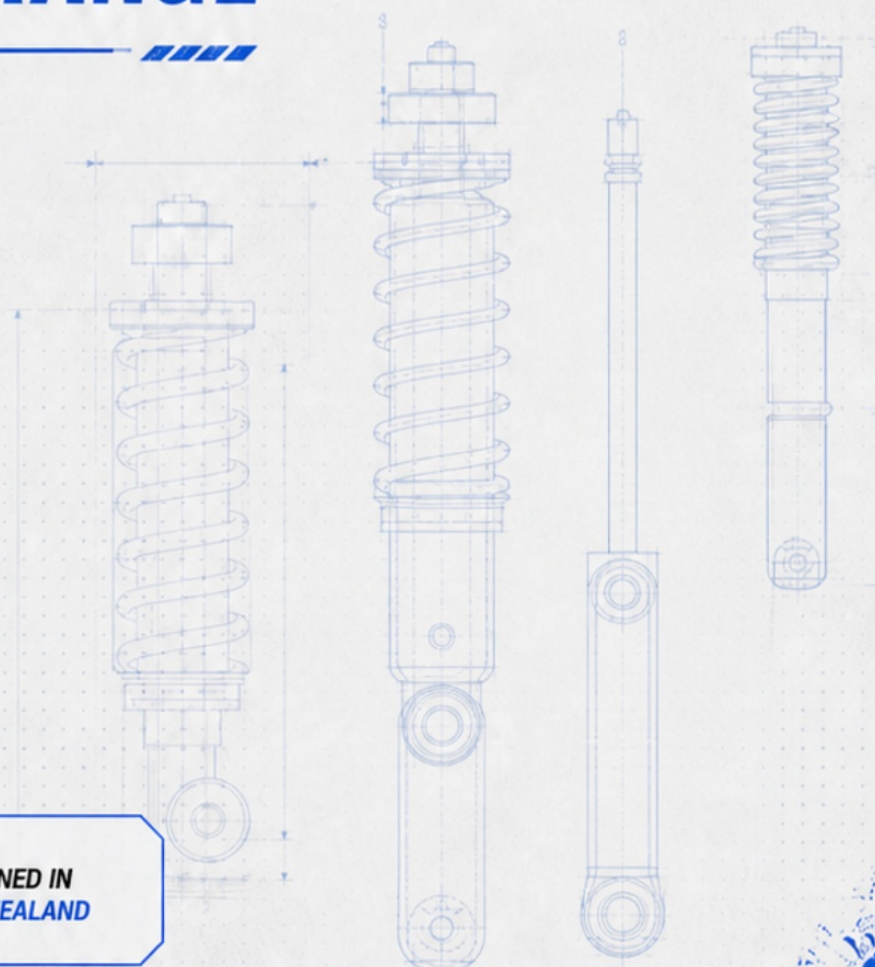

**3 YEAR
LIMITED FACTORY
WARRANTY**



**PROUDLY
NEW ZEALAND
OWNED & OPERATED**



**BUILT FOR
4WD
CONDITIONS**



MOUNTAIN SERIES SPECIFICATIONS

A MOUNTAIN SERIES IFS STRUT STYLE SHOCKS

Designed for Independent Front Suspension (IFS) systems, these strut style shocks enhance ride height, handling and stability on and off-road. With a 2.25-inch shock body, 20 mm shock shaft and 35 mm bore, they deliver strength, durability and consistent performance. Filled with nitro gas and Mitsubishi shock racing oil, and sealed with NOK Japan oil seals and O-rings for reliable, long-lasting performance.

- ✓ 2.25" Shock Body
- ✓ 35mm Bore Size
- ✓ Nitro Gas Filled
- ✓ Twin Tube Steel Body Shock Design
- ✓ Adjustable Height Spacers Included
- ✓ 20mm Shock Shaft
- ✓ Lubricants and Oils by Mitsubishi Shock Racing Oil
- ✓ High Quality NOK Japan Oil Seals & O-rings
- ✓ 3 Year Limited Factory Warranty



B MOUNTAIN SERIES NON-IFS SHOCKS

Built for reliable, consistent performance across a wide range of off-road conditions. These shocks feature a 2.25-inch shock body, 20 mm shock shaft and 35 mm bore for superior strength and durability. Filled with nitro gas and Mitsubishi shock racing oil, and sealed with NOK Japan oil seals and O-rings to deliver dependable suspension performance every time.

- ✓ 2.25" Shock Body
- ✓ 35mm Bore Size
- ✓ Nitro Gas Filled
- ✓ Twin Tube Steel Body Shock Design
- ✓ 20mm Shock Shaft
- ✓ Lubricants and Oils by Mitsubishi Racing Shock Oil
- ✓ High Quality NOK Japan Oil Seals & O-rings
- ✓ 3 Year Limited Factory Warranty



BUILT TOUGH.
BUILT FOR 4WD.



DESIGNED IN
NEW ZEALAND



PROUDLY
NEW ZEALAND
OWNED & OPERATED



BUILT FOR
4WD
CONDITIONS



ENGINEERED FOR ADVENTURE

From rocky tracks to long highway hauls, Xtreme Gravel Gear™ Mountain Series shocks give you the confidence, comfort and control to go further. Built tough for touring, towing and off-road driving—so you can tackle every journey with ease



**3 YEAR
LIMITED FACTORY
WARRANTY**



**PROUDLY
NEW ZEALAND
OWNED & OPERATED**



**BUILT FOR
4WD
CONDITIONS**

WHY CHOOSE MOUNTAIN SERIES?



TWIN-TUBE STEEL BODY DESIGN

Robust twin-tube construction delivers superior strength and long-lasting durability.



2.25" SHOCK BODY

Large 2.25-inch shock body provides greater oil capacity for consistent performance.



35MM BORE SIZE

35mm internal bore improves oil flow and cooling for better shock absorption.



20MM HEAVY-DUTY SHOCK SHAFT

20mm shock shaft adds strength and stability when you need it most.



NITRO GAS FILLED

Nitro gas charge prevents cavitation and maintains consistent damping.



MITSUBISHI RACING SHOCK OIL

Premium Mitsubishi racing oil ensures smooth performance and heat resistance.



HIGH-QUALITY NOK JAPAN OIL SEALS & O-RINGS

NOK Japan seals and O-rings prevent leaks and extend shock life.



CONSISTENT DAMPING & HEAT RESISTANCE

Engineered for steady control and durability in the toughest off-road conditions.



PRO SERIES MONO TUBE SHOCKS

SPECIFICATIONS

A

PRO SERIES ADJUSTABLE COIL-OVER SHOCKS

Pre-assembled adjustable coil-over shock absorbers featuring a 2.5-inch shock body standard and 22 mm shock shaft, designed for rugged off-road driving. Adjustable, durable and built to deliver superior ride stability and reliability across demanding terrain.

- ✓ Adjustable Coil Spring
- ✓ 2.5" Shock Body
- ✓ (Some vehicle models use 2.25 shock body)
- ✓ Valved to suit your vehicle
- ✓ 22mm Shock Shaft
- ✓ Internal Floating Piston (IFP)
- ✓ Nitro Gas Filled
- ✓ Pre-Assembled with Coil Spring
- ✓ Lubricants and Oils by Fuchs Germany Racing shock oil
- ✓ High Quality NOK Japan Oil Seals and O-rings
- ✓ 3 Year Limited Factory Warranty



B

PRO SERIES SHOCKS

High-quality shock absorbers with a 2.5 inch shock body standard and 22 mm shock shaft, engineered for superior durability and control in demanding off-road conditions.

- ✓ 2.5" Shock Body standard
- ✓ Valved to suit your vehicle
- ✓ 22mm Shock Shaft
- ✓ Internal Floating Piston (IFP)
- ✓ Nitro Gas Filled
- ✓ Lubricants and Oils by Fuchs Germany Racing shock oil
- ✓ High Quality NOK Japan Oil Seals and O-rings
- ✓ 3 Year Limited Factory Warranty



BUILT TOUGH.
BUILT FOR 4WD.



DESIGNED IN
NEW ZEALAND



PROUDLY
NEW ZEALAND
OWNED & OPERATED



BUILT FOR
4WD
CONDITIONS



PRO SERIES

ENGINEERED FOR ADVENTURE

From technical tracks to wide-open trails, Xtreme Gravel Gear™ Pro Series shocks give you the control, durability and confidence to push harder. Built tough for serious 4WD adventure—so you can go further, for longer, with total confidence.

WHY CHOOSE PRO SERIES?



MONO-TUBE SHOCK DESIGN

Built for dependable damping and long-lasting control in rugged conditions.



2.5" SHOCK BODY

Some vehicle models use a 2.25" body.



22MM SHOCK SHAFT

Heavy-duty shaft for strength and durability.



INTERNAL FLOATING PISTON (IFP)

Helps maintain consistent damping and oil separation for reliable suspension.



NITRO GAS FILLED

Helps reduce fade and maintains steady control.



FUCHS GERMANY RACING SHOCK OIL

Premium racing oil for improved heat resistance and long-lasting suspension capability.



HIGH-QUALITY NOK JAPAN OIL SEALS & O-RINGS

Helps prevent leaks and extend service life.



VALVED TO SUIT YOUR VEHICLE

Tuned for your vehicle and driving needs.

PRO SERIES

FULLY SERVICEABLE & REBUILDABLE

The Xtreme Gravel Gear Pro Series range is engineered for long-term performance, easy servicing, and rebuildability.



- ✓ Built for the long haul
- ✓ Easy maintenance
- ✓ Long-term value

PRO X SERIES MONO TUBE SHOCKS

SPECIFICATIONS

A



PRO X COIL OVERS 2.5 ADJUSTABLE COIL-OVER SHOCKS

Pre-assembled adjustable coil-over shocks with a 2.5-inch shock body standard, 22mm shock shaft and rebound damping adjustment. Adjustable coil spring, valved to suit your vehicle and built with internal floating piston (IFP), nitro gas, Fuchs Germany racing shock oil and NOK Japan oil seals & O-rings. Backed by a 3-year limited factory warranty.

FEATURES

- Adjustable Coil Spring
- 2.5" Shock Body Standard
- 14 to 24 Stage Rebound Adjustment (Depending on Vehicle)
- Valved to Suit Your Vehicle
- 22mm Shock Shaft
- Internal Floating Piston (IFP)
- Nitro Gas Filled
- Pre-Assembled with Coil Spring
- Fuchs Germany Racing Shock Oil
- High Quality NOK Japan Oil Seals & O-rings
- 3 Year Limited Factory Warranty

B



PRO X SERIES 2.5 SHOCKS

2.5 inch shock body standard with rebound damping adjustment, valved to suit your vehicle and built with 22mm shaft, internal floating piston (IFP), nitro gas, Fuchs Germany racing shock oil and NOK Japan oil seals and O-rings. Backed by a 3-year limited factory warranty.

- 2.5" Shock Body standard
- 14 to 24 stage Rebound damping adjustment (depending on vehicle)
- Valved to suit your vehicle
- 22mm Shock Shaft
- Internal Floating Piston (IFP)
- Nitro Gas Filled
- Lubricants and Oils by Fuchs Germany Racing shock oil
- High Quality NOK Japan Oil Seals and O-rings
- 3 Year Limited Factory Warranty



ENGINEERED FOR ADVENTURE

Built for demanding 4WD use, Xtreme Gravel Gear Pro Series shocks help reduce excessive bouncing, improve stability and keep your vehicle controlled on rough roads, touring routes, everyday driving, towing, and carrying heavy loads.



Rebound
Adjustment



Reduces
Excessive
Bouncing



Improves
Stability



Built for
Towing &
Heavy Loads



REBOUND ADJUSTMENT 14 TO 24 STAGES

WHY CHOOSE PRO X SERIES?



**SUITABLE FOR
VEHICLES CARRYING
HEAVY LOADS**

Built to handle extra weight with confidence and control.



**DESIGNED FOR
TOWING**

Built tough for towing applications and demanding loads.



**REDUCES EXCESSIVE
BOUNCING**

Helps minimise bounce for a smoother, more controlled ride.



**IMPROVES
STABILITY**

Enhances stability for better handling on all terrains.



**MONO-TUBE
SHOCK DESIGN**

Provides dependable damping control and excellent heat management.



**2.5" SHOCK BODY
STANDARD**

2.25" used based on vehicle fitment.



**22MM
SHOCK SHAFT**

Heavy-duty shaft for strength and durability.



**INTERNAL FLOATING
PISTON (IFP)**

Helps maintain consistent damping and oil separation.



**NITRO GAS
FILLED**

Helps reduce fade and maintains steady control.



**FUCHS GERMANY
RACING SHOCK OIL**

Premium racing oil for improved heat resistance and long-lasting performance.



**HIGH-QUALITY NOK
JAPAN OIL SEALS
& O-RINGS**

Helps prevent leaks and extends service life.



**SPANNERS FOR
ADJUSTMENT
SUPPLIED**

Adjust with confidence – spanners included.

FULLY SERVICEABLE & REBUILDABLE

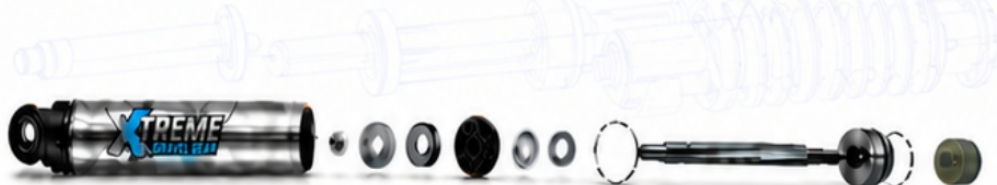

The Pro Series range is engineered for long-term performance, easy servicing, and rebuildability.



Built for the long haul



Easy maintenance



Long-term value

PRO XS SERIES

SPECIFICATIONS

A



PRO XS SERIES 2.5 ADJUSTABLE COIL-OVER SHOCKS

Pre-assembled adjustable coil-over shock absorbers with external reservoirs featuring a 2.5-inch shock body, 22mm shock shaft, and 24-stage compression damping adjustment. Designed for demanding off-road use, these shocks are valved to suit your vehicle and built with internal floating piston (IFP), nitro gas, Fuchs Germany racing shock oil, and high-quality NOK Japan oil seals and O-rings.

- Adjustable Coil Spring
- 2.5" Shock Body standard
- 24 stage Compression damping adjustment
- Remote reservoir or fixed reservoir vehicle specific
- Valved to suit your vehicle
- 22mm Shock Shaft
- Internal Floating Piston (IFP)
- Nitro Gas Filled
- Pre-Assembled with Coil Spring
- Lubricants and Oils by Fuchs Germany Racing shock oil
- High Quality NOK Japan Oil Seals and O-rings
- 3 Year Limited Factory Warranty



Adjustable
Spring Seat



24-Stage
Compression Dial



External
Reservoir

B

PRO XS SERIES 2.5 SHOCKS

High-quality shock absorbers with a 2.5 inch shock body standard and 22mm shock shaft, engineered for superior control, durability and off-road performance. Features 24-stage compression damping adjustment and vehicle-specific remote or fixed reservoir configurations, valved to suit your vehicle. Built with internal floating piston (IFP), nitro gas, Fuchs Germany racing shock oil, and high-quality NOK Japan oil seals and O-rings.

- 2.5" Shock Body standard
- 24 stage Compression damping adjustment
- Remote reservoir or fixed reservoir vehicle specific
- Valved to suit your vehicle
- 22mm Shock Shaft
- Internal Floating Piston (IFP)
- Nitro Gas Filled
- Lubricants and Oils by Fuchs Germany Racing shock oil
- High Quality NOK Japan Oil Seals and O-rings
- 3 Year Limited Factory Warranty



24 Stage Compression
Damping Adjustment



Fixed Reservoir



Remote Reservoir





ENGINEERED FOR EXTREME ADVENTURE

Built for serious off-road drivers, Xtreme Gravel Gear™ Pro XS Series shocks deliver outstanding control, strength and damping performance in extreme terrain. With advanced compression adjustment and reservoir-equipped performance, Pro XS gives you the confidence to push further.



24-Stage
Compression
Damping



Improves
Stability



Ideal for
Top-Heavy
Loads



REMOTE RESERVOIR 24 STAGE COMPRESSION ADJUSTMENT

WHY CHOOSE PRO XS SERIES?



24-STAGE COMPRESSION DAMPING

Dial in suspension response for improved control across rough terrain.



EXTERNAL RESERVOIR

Remote or fixed reservoir options depending on vehicle for added oil capacity and heat control.



2.5" SHOCK BODY

Large 2.5-inch shock body for strength, durability and increased oil volume.



22MM SHOCK SHAFT

Heavy-duty 22mm shaft built to handle demanding off-road conditions.



INTERNAL FLOATING PISTON (IFP)

Helps separate oil and gas for consistent damping feel.



NITRO GAS FILLED

Supports reliable shock response and helps reduce fade.



FUCHS GERMANY RACING SHOCK OIL

Premium shock oil for smooth damping and heat resistance.



NOK JAPAN OIL SEALS & O-RINGS

Quality sealing components designed to help prevent leaks.



VALVED TO SUIT YOUR VEHICLE

Vehicle-specific valving to suit your setup and driving needs.



3 YEAR LIMITED FACTORY WARRANTY

Backed by a 3 year limited factory warranty for added confidence.



ASSISTS WITH BODY ROLL

Ideal for vehicles with top-heavy loads



FULLY SERVICEABLE & REBUILDABLE



The Pro Series range is engineered for long-term performance, easy servicing, and rebuildability.



Built for the long haul



Easy maintenance



Long-term value

PRO XL SERIES SPECIFICATIONS

A PRO XL SERIES 2.5 ADJUSTABLE COIL-OVER SHOCKS

Xtreme Gravel Gear Pro XL Series coil-over shocks are our flagship all-rounder suspension system, built for Baja-style off-roading, overlanding, touring and long-haul 4WD use. Featuring 24-stage compression damping and 14 to 24-stage rebound adjustment depending on vehicle, they deliver premium control, durability and consistent performance in demanding conditions.

- ✓ Adjustable Coil Spring
- ✓ 2.5" Shock Body Standard
- ✓ 24 Stage Compression Damping Adjustment
- ✓ 14 to 24 Stage Rebound Damping Adjustment (Depending on Vehicle)
- ✓ Remote Reservoir with 24 Stage Compression Adjustment
- ✓ Valved to Suit Your Vehicle
- ✓ 22mm Shock Shaft
- ✓ Internal Floating Piston (IFP)
- ✓ Nitro Gas Filled
- ✓ Pre-Assembled with Coil Spring
- ✓ Phriltants and Oils by Fuchs Germany Racing Shock Oil
- ✓ High Quality NDK Japan Oil Seals and O-rings
- ✓ 3 Year Limited Factory Warranty



REBOUND DAMPING ADJUSTMENT

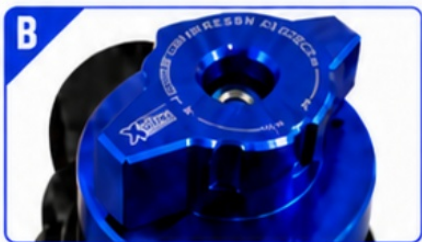

COMPRESSION DAMPING ADJUSTMENT

B PRO XL SERIES 2.5 ADJUSTABLE SHOCKS

Xtreme Gravel Gear Pro XL Series adjustable shocks are a flagship high-performance suspension system designed for demanding off-road use. Featuring 24-stage compression damping and 14 to 24-stage rebound damping depending on vehicle, they deliver precise control, durability and consistent performance in challenging conditions. Available with a remote reservoir or fixed reservoir depending on vehicle, and built with a large 2.5-inch shock body and 22mm shock shaft, they are engineered for serious off-road performance.

- ✓ 2.5" Shock Body Standard
- ✓ 24 Stage Compression Damping Adjustment
- ✓ 14 to 24 Stage Rebound Damping Adjustment (Depending on Vehicle)
- ✓ Remote Reservoir or Fixed Reservoir (Vehicle Specific)
- ✓ Valved to Suit Your Vehicle
- ✓ 22mm Shock Shaft
- ✓ Internal Floating Piston (IFP)
- ✓ Nitro Gas Filled
- ✓ Phriltants and Oils by Fuchs Germany Racing Shock Oil
- ✓ High Quality NDK Japan Oil Seals and O-rings
- ✓ 3 Year Limited Factory Warranty



REBOUND DAMPING ADJUSTMENT



COMPRESSION DAMPING ADJUSTMENT

WHY CHOOSE PRO XL SERIES?

FLAGSHIP PERFORMANCE FOR EVERY ADVENTURE

From Baja-style off-roading to overlanding, touring and long-haul 4WD travel, Xtreme Gravel Gear™ Pro XL Series shocks deliver premium control, durability and confidence across every terrain.



DUAL DAMPING CONTROL



REMOTE OR FIXED RESERVOIR



PREMIUM CONTROL & DURABILITY



1. FLAGSHIP ALL-ROUNDER

Engineered to perform across Baja-style off-roading, overlanding, touring and daily adventure use.



2. DUAL DAMPING CONTROL

24-stage compression damping and 14 to 24-stage rebound adjustment depending on vehicle.



3. 2.5" SHOCK BODY

Large 2.5-inch shock body helps manage heat and maintain consistent performance.



4. 22MM SHOCK SHAFT

Heavy-duty 22mm shaft delivers superior strength and durability in demanding conditions.



5. REMOTE OR FIXED RESERVOIR

Vehicle-specific reservoir configuration for improved cooling and performance.



6. ADJUSTABLE COIL SPRING

Pre-assembled adjustable coil-over design allows easy ride height tuning and setup flexibility.



7. PREMIUM INTERNALS

Internal Floating Piston (IFP), nitro gas fill, Fuchs Germany racing shock oil, and NOK Japan seals.



8. VALVED TO SUIT YOUR VEHICLE

Tuned to match your application for confident handling, comfort and control.

BUILT FOR SERIOUS OFF-ROADERS WHO WANT PREMIUM PERFORMANCE WITHOUT COMPROMISE.

PRO XL SERIES

FULLY SERVICEABLE & REBUILDABLE

The Xtreme Gravel Gear Pro XL Series range is engineered for long-term performance, easy servicing, and rebuildability.



Built for the long haul



Easy maintenance



Long-term value



3 YEAR LIMITED FACTORY WARRANTY

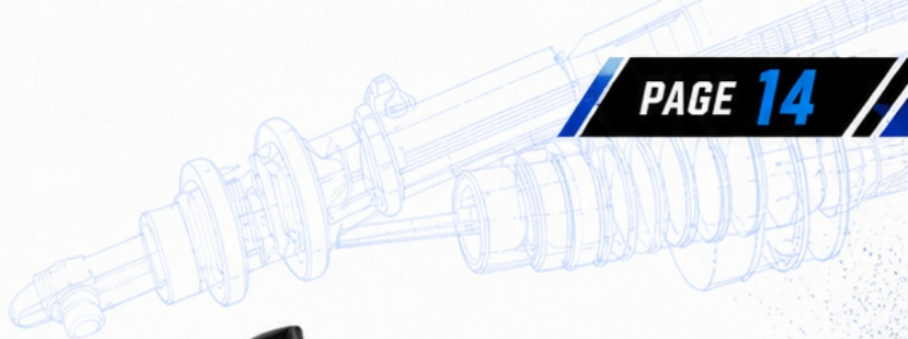

/// XTREME GRAVEL GEAR ///

COIL SPRINGS

ENGINEERED FOR STRENGTH,
COMFORT AND LOAD CONTROL



Xtreme Gravel Gear coil springs are engineered to deliver dependable ride height, load support and long-term durability. Built as the foundation of a capable suspension setup, each spring is manufactured from premium-grade steel, cold-wound for consistency, and load-tested before leaving the factory. Designed for specific vehicle applications and varying load requirements, Xtreme Gravel Gear coil springs help improve comfort, control and confidence on-road and off-road. Whether your vehicle is used for touring, trade or everyday driving, our coil spring range is built to perform. Backed by a 3 year limited factory warranty and supported through our dealer network, Xtreme Gravel Gear gives you strength you can rely on.



PREMIUM-
GRADE STEEL



COLD-WOUND
FOR CONSISTENCY



LOAD-TESTED
BEFORE DISPATCH



VEHICLE-SPECIFIC
APPLICATIONS



DESIGNED FOR
VARYING LOAD
RATINGS



IMPROVED
RIDE HEIGHT &
HANDLING



BUILT FOR
ON-ROAD &
OFF-ROAD USE



3 YEAR LIMITED
FACTORY
WARRANTY



STRONGER. SMOOTHER. BUILT FOR EVERY ADVENTURE.



XTREME[®] GRAVEL GEAR

WWW.XTREMEGRAVELGEAR.COM

DID YOU KNOW?

XTREME GRAVEL GEAR OFFERS MORE THAN JUST SHOCKS.

We supply a wide range of high-quality suspension components built for touring, off-road performance, upgrades and replacement needs across a variety of 4WD vehicles.



ADDITIONAL SUSPENSION COMPONENTS WE OFFER >>>



LEAF SPRINGS



CONTROL ARMS –
BILLET & MILD STEEL



TRAILING ARMS



BILLET ADJUSTABLE
STABILIZER LINKS



STEERING DAMPERS



ADJUSTABLE
BUMP STOPS



**INQUIRE DIRECTLY
FOR MORE INFORMATION.**



REMEMBER

TO USE THE XTREME GRAVEL GEAR
SUSPENSION FINDER ON OUR WEBSITE
TO FIND WHAT SHOCKS FIT YOUR VEHICLE.



WWW.XTREMEGRAVELGEAR.COM

XTREME
GRAVEL GEAR



XTREME GRAVEL GEAR

RECOVERY GEAR

PRODUCTS INTRODUCTION

Xtreme Gravel Gear recovery gear is built to help drivers stay prepared when the unexpected happens. Engineered for demanding off-road conditions, our gear delivers the confidence, durability, and practical support you need to get back on track and keep the adventure going.



BUILT TOUGH

Made from high-quality, hard-wearing materials that stand up to harsh off-road conditions.



RECOVERY READY

Designed to perform when it matters most, helping you get out of tough situations.



OFF-ROAD CONFIDENCE

Gear you can rely on to handle challenging terrains with strength and dependability.



DESIGNED FOR ADVENTURE

Practical, reliable gear that's made for drivers who explore beyond the beaten path.



Contact us for more information on the Xtreme Gravel Gear recovery gear range.



BE PREPARED
WHEN THE TRACK GETS TOUGH.

WWW.XTREMEGRAVELGEAR.COM

XTREME GRAVEL GEAR

RECOVERY SNATCH STRAPS



15T NYLON SNATCH STRAP

A heavy-duty recovery strap designed to help recover bogged vehicles with controlled stretch and dependable durability.

- 15T breaking strength
- Up to 20% stretch
- 9M length
- Heavy-duty nylon construction
- Ideal for difficult bogged recoveries

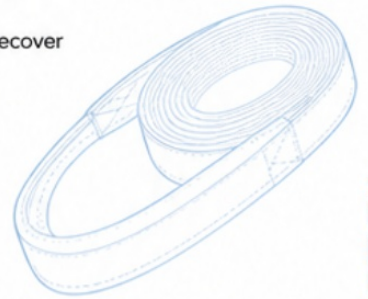

8T NYLON SNATCH STRAP

A durable recovery strap built for off-road situations, providing the controlled stretch needed for effective vehicle recovery.

- 8T breaking strength
- Up to 20% stretch
- 9M length
- Heavy-duty nylon construction
- Built for tricky bogged situations

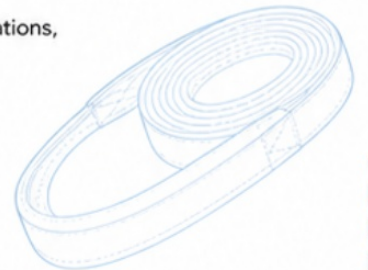

16T TREE TRUNK PROTECTOR

A heavy-duty tree trunk protector designed for winching applications, helping distribute the load while protecting trees and recovery gear.

- 16T rated breaking strength
- 2M length
- Heavy-duty polyester webbing
- Helps spread load evenly when winching
- Protects trees and recovery equipment



BUILT FOR **SERIOUS RECOVERY SITUATIONS**

A SYNTHETIC WINCH ROPE



The Xtreme Gravel Gear™ Synthetic Winch Rope is the safest and most reliable upgrade for your 4WD winch. Engineered for strength, durability and ease of use, it delivers dependable performance when you need it most.

- Available in 9mm x 30m – 15,400 lbs breaking strength
- Available in 10mm x 30m – 17,500 lbs breaking strength
- Lightweight synthetic construction for safer winching
- Resistant to kinks, curls and splinters common with steel cable
- Easy to handle and convenient to use
- Made from premium raw materials sourced from the USA
- Braided on German-made machinery for precision and durability
- Ideal upgrade for dependable 4WD winch recoveries

B 8T SPLIT D SHACKLE



The Xtreme Gravel Gear™ Split D Shackle is the ultimate solution for off-road enthusiasts who value both convenience and reliability. This innovative D shackle allows you to keep it mounted to your rig at all times, eliminating the hassle of removing it for recoveries. Simply split the shackle, hook up your tow rope or soft shackle, and you're ready to go.

SKU: XGG-SDS-RB-001

- Innovative split design for quick attachment
- 8-ton load rating for demanding recoveries
- Can be kept mounted on your rig for convenience
- Compatible with tow ropes or soft shackles
- Includes bolts and spacers for installation
- Durable, reliable construction for tough off-road use
- Versatile and ready for a wide range of recovery scenarios

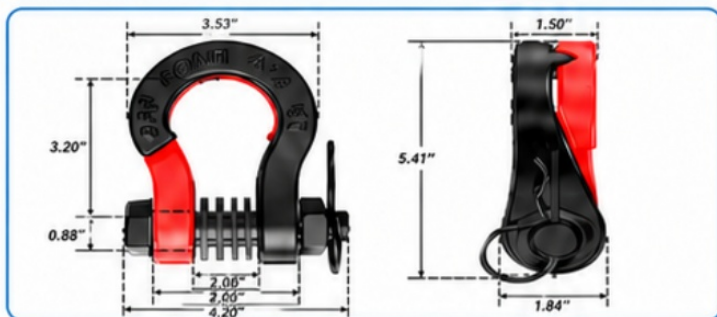

QUICK ATTACHMENT

Split design for fast and easy use



HEAVY-DUTY RECOVERY

Built strong for extreme conditions



SAFER WINCHING

Lightweight synthetic for safer recoveries



BUILT FOR 4WD USE

Engineered for off-road reliability



WWW.XTREMEGRAVELGEAR.COM

BUILT FOR SERIOUS OFF-ROADERS. READY FOR ANYTHING.

From premium shocks to reliable recovery gear, Xtreme Gravel Gear™ delivers the strength, control and confidence you need to go further, tackle tougher terrain and come back stronger.



PREMIUM QUALITY

Engineered using high-grade materials for maximum performance and durability.



TESTED. TRUSTED. TOUGH.

Rigorously tested in real-world conditions so you can rely on every product.



BUILT FOR ADVENTURE

Designed for Baja-style off-roading, overlanding, touring and long-haul 4WD.



SUPPORT YOU CAN COUNT ON

Backed by a 3 Year Limited Warranty and a team that's here to help.

THANK YOU

FOR CHOOSING XTREME GRAVEL GEAR™

We appreciate your support and look forward to being part of your next adventure.

EXPLORE FURTHER. RECOVER SMARTER. DRIVE XTREME.



VISIT OUR WEBSITE

www.xtremegravelgear.com



EMAIL US

inquiries@xtremegravelgear.com



FOLLOW US

[@xtremegravelgear](https://www.instagram.com/xtremegravelgear)